

Cyclone separator Z 20N to Z 375



Z 20N - Z 250N



Z 375

LAYOUT

The cyclone separator is ideally suited as a bulk water separator when located before a refrigerant dryer or directly after the compressor if no air receiver is used; or if it is placed at a distance; or if the compressed air supply pipe is mounted vertically.

EFFICIENCY

Apart from the drain, the cyclone separator operates wear-free because there are no moving parts which means increased output of the compressed air-treatment system.

MINIMAL PRESSURE LOSS

There is a minimal pressure loss across a cyclone separator, which means that operating pressure is always optimised – saving energy.

BEKOMAT

An electronically level-controlled, loss-free, Bekomat condensate drain can be fitted as an option assuring increased compressed air treatment safety.

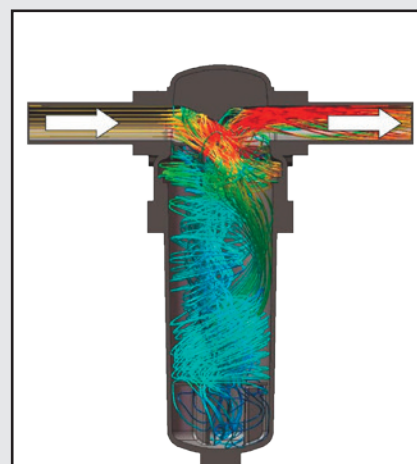

OPERATING PRINCIPLE

The cyclone separator works according to the mass inertia principle. It consists of a vortex cartridge and a reservoir. The vortex cartridge induces the compressed air into rotary movement. Solid and liquid components in the air are forced against the inside walls of the separator by their own mass inertia. This causes heavy particles of dirt and water to separate and flow into the collection reservoir.

Maintenance-free filtration: The BOGE heavy-duty cyclone separators take liquids, aerosols and solids from the compressed air. Based on the physical law of inertia they operate with practically no maintenance – ideally suited to compressed air systems without an air receiver when installed directly downstream of the compressor.

BOGE Compressed Air Systems GmbH & Co. KG

P. O. Box 10 07 13 · 33507 Bielefeld, Germany

Otto-Boge-Straße 1–7 · 33739 Bielefeld, Germany

phone +49 5206 601-0

fax +49 5206 601-200

info@boge.com · www.boge.com

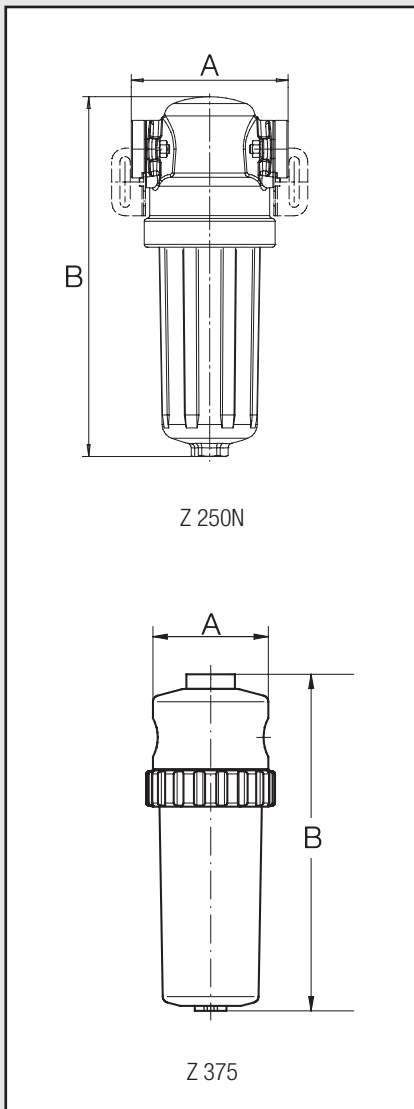

BOGE model	Flow capacity* m ³ /min at			Compressed air connection	Max. operating pressure bar	Dimensions	
	8 bar	10 bar	13 bar			A mm	B mm
Z 20N	2.26	2.80	3.50	G ½	16	103	238
Z 35N	3.95	4.83	6.13	G ¾	16	139	324
Z 53N	6.03	7.36	9.33	G 1	16	139	324
Z 75N	8.48	10.35	13.13	G 1½	16	190	528
Z 125N	14.13	17.28	21.88	G 2	16	190	528
Z 183N	20.72	25.30	32.08	G 2	16	190	528
Z 250N	28.25	34.50	43.75	G 2½	16	248	580
Z 375	41.25	52.92	65.63	G 3	16	248	580

* relates to the compressor's intake condition (+20°C, 1 bar)